

TRX-1220-B Multi-Lane Transceiver for Dedicated Short Range Communication (DSRC)



The transceiver TRX-1220-B is a roadside device for communication with on-board units (OBU) or transponders (TRP) that follow DSRC standards according to CEN TC278. Full compliance with CEN DSRC standards and public documents like Global Specification for Short Range Communication (GSS), A1, Cardme 4 and Cesare II secures that interoperability with other EFC systems is achieved.

Within its core field of applications the TRX-1220-B is ideally suited for real multi-lane free-flow systems. Up to 8 transceivers can be connected in star or line topology to form a DSRC subsystem for the coverage of virtually any variant of road width. The DSRC subsystem interconnects via standard Ethernet interface to a lane controller or directly to a back office system.

The special bus system (IBB = Inter Beacon Bus) developed by Kapsch is optimized for MLFF environment. It ensures bit synchronous data transmission on all transceivers within the DSRC subsystem. The downlink data are synchronized to avoid interferences at the OBUs. The IBB protocol is a master/slave protocol with the transceiver controller TRC acting as the master and the transceivers acting as slaves. The transceivers are controlled by the TRC which coordinates the access to the bus and the transmission of the DSRC-Downlink frames.

After transmission of the DSRC data in the Downlink, the transceivers switch over to receiving uplink data from the OBU/TRP. The IBB protocol maintains a store and forward process in each transceiver. Data received are sent to the lane controller at the end of the Uplink phase within a dynamic TDMA scheme. The

protocol dynamically observes the communication load and optimises the data throughput on the bus. Full performance at maximum vehicle speed is guaranteed even with several OBU/TRP passing the toll station simultaneously.

Antenna Characteristics

The built-in circular polarized antenna system consists of a receiving and a transmitting antenna designed in planar in microstrip technology. Electrical beam shaping is realized by combining the individual patches to a “phased array”. Two basic characteristics are available. For details please refer to the technical data.

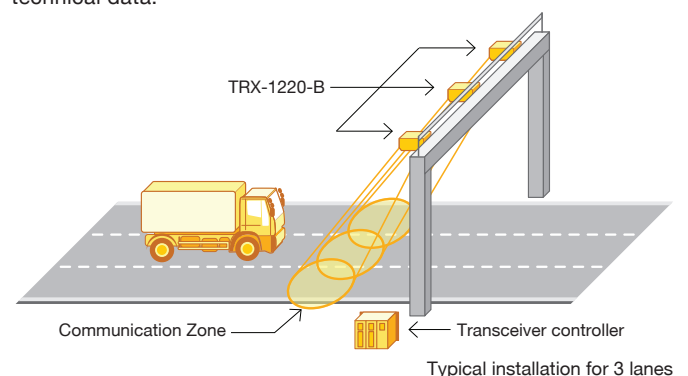

Communication Zone

The communication zone is defined as the area in which the BER (Bit Error Rate) of the communication between the transceiver and on-board equipment is below 10⁻⁶. Besides the electrical characteristics of transceivers and OBUs size and shape of the communication zone depend mainly on the installation geometry e.g. installation height and down-tilt of the transceiver as well as the mounting position of the OBU/TRP. At a TRX installation height of 5.5 m and an OBU/TRP mounting height of 1.3 m a typical communication zone of the of the TRX-1220-B covers a 3 m x 4 m (length x width) zone of nearly elliptical shape.

- Fully CEN/DSRC CEN TC278 standards compliant
- GSS - Global Specification for Short Range Communication conformity
- Compliant with CESARE II (specification for interoperable toll systems issues by the Association of European Toll Road Operators (ASECAP)
- Interoperable with any CEN/DSRC compliant on-board equipment
- Overlapping communication zones to provide full coverage without black holes
- Redundant coverage on demand
- Weather resistant, robust and compact housing complying IP67

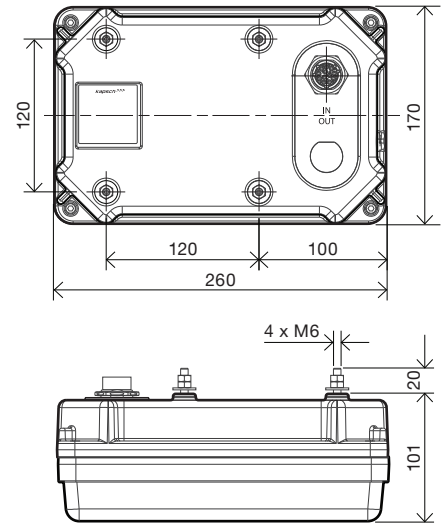

Measurements in mm.

Features (Including TRC)

- Optimized for multi-lane applications
- Up to 8 transceivers can be connected together. This corresponds to an application for e.g.
 - 7 lanes and 1 service lane
- Star or line topology support

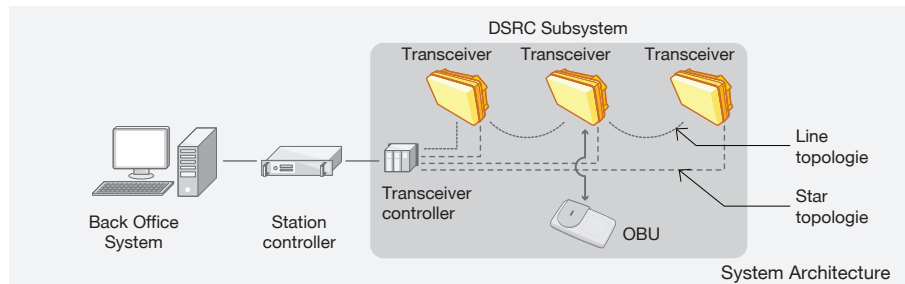

Technical Features

Casing

- Aluminium die casting
- Protection classification: IP 67

Dimensions

- 260 x 170 x 110 mm.

Weight

- 3 kg.

Temperature range

- Storage: -40°C - +70°C
- Operation: -33°C - +55°C

Vibration

- 3,5 mm / (1 .. 9) Hz
- 10 m/s² / (9 .. 150) Hz

Shock

- 150 m/s² / 11ms

Mounting position

- 2,5 m – 6,5 m above road

Electrical

- Frequency Range: 5.795 GHz – 5.815 GHz
- Channel 1: 5.7975 GHz ±2.5 MHz
- Channel 2: 5.8025 GHz ±2.5 MHz
- Channel 3: 5.8075 GHz ±2.5 MHz
- Channel 4: 5.8125 GHz ±2.5 MHz
- Data Rate (down-/uplink): 500 kbit/s / 250 kbit/s
- Voltage of power supply: 24 VDC - 48 VDC
- Power consumption: 11 W / 4 W standby
- Radiated power: ≤ +33dBm EIRP
- Security
- Security encryption: DES, 3DES

Total memory TRX1x20-B

- Flash memory: 4MB
- SDRAM: 16 MB
- Non-volatile RAM real time clock: n. a.

Interface

- Inter Beacon Bus (IBB)

Antenna characteristics

- Antenna polarization: left hand circular
- Typical communication zone at a mounting height of 5.5 m, centre of lane
 - Truck TRX1220-B, OBU: Width: 3m / Length: 3 m (elliptical)
 - Truck TRX1320-B, OBU: Width: 2m / Length: 3 m (elliptical)
 - Car TRX1220-B, OBU: Width: 4m / Length: 3 m (elliptical)
 - Car TRX1320-B, OBU: Width: 3m / Length: 3 m (elliptical)

Variants TRX-1x20-B/y

- x:
 - = 2: wide communication zone
 - = 3: narrow communication zone
- y:
 - = S: Star topology
 - = L: Line topology

Kapsch Group

The companies of the Kapsch Group – Kapsch TrafficCom, Kapsch CarrierCom and Kapsch BusinessCom – are leading the international markets for Intelligent Transportation Systems (ITS) and Information and Communication Technologies (ICT). Kapsch. Always one step ahead.