

OPS-1955

On-Board Unit Programming Station



The OPS-1955 is part of the Kapsch TrafficCom communication devices family TS3200-09 for CEN (European committee for standardization) DSRC (Dedicated Short Range Communication) 5.8 GHz based applications.

The OPS-1955 is a device used for programming on-board units (OBUs/TRPs) with operator and user data. This “personalization” prepares the OBUs for their use in electronic toll systems.

General system overview

An on-board unit (OBU) needs to be programmed with specific technical data to use it in an electronic toll collection system.

The OPS-1955 is a compact communication device for data exchange between the PC of the distribution point and the OBU, in accordance with the DSRC TC 278 standard. The data between the OPS-1955 and the OBU are exchanged through the DSRC interface, which fully complies with the CEN standards for DSRC and EFC, and with the GSS specifications used by the DSRC dedicated antenna.

The DSRC communication is optimised in two operation modes: the personalization mode, in which the OPS-1955 receives the

data from the computer and a power saving DSRC link, which transmits such data to a new or previously personalized OBU. If there is no communication with the OBU, the OPS is switched to “Stand by” mode, in which the DSRC link remains inactive and closed, i.e. there is no radiofrequency transmission.

Designed to be used in an office environment, the OPS-1955 is a compact device that uses USB connection of high speed 2.0 for data exchange and power supply. It can also be connected to an external power source.

In an attempt to facilitate its use, the OPS-1955 has a LED at the top indicating the different functional states through different colours: ready, personalization and error; and a detector of presence of objects,

located at the top of the device, which makes it easier to locate the OBU for its detection.

For the sake of security and codification, passwords manipulation is made through a net or a SAM card reader connected to the PC of the Distribution Point.



Features

- Easy to use device; can be used with one hand
- Small enough to be placed on office desks
- It does not have mobile parts
- Non-slip protection
- Easy to clean
- USB connection for data exchange and power supply
- Maximum size of OBUs: 75 x 120 mm (width by height)
- Object detector in the reading surface

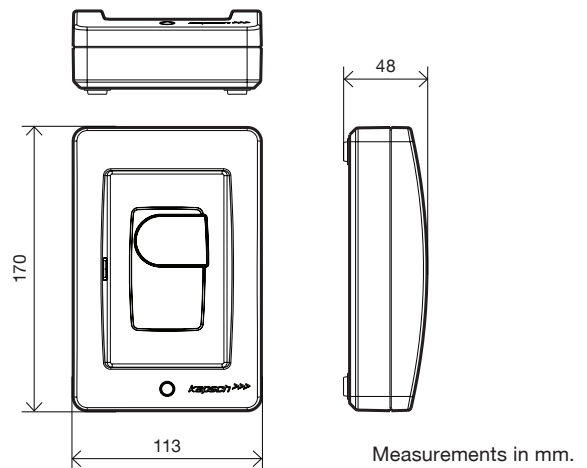

© Kapsch TrafficCom AG. Subject to alteration without prior notice.

System architecture

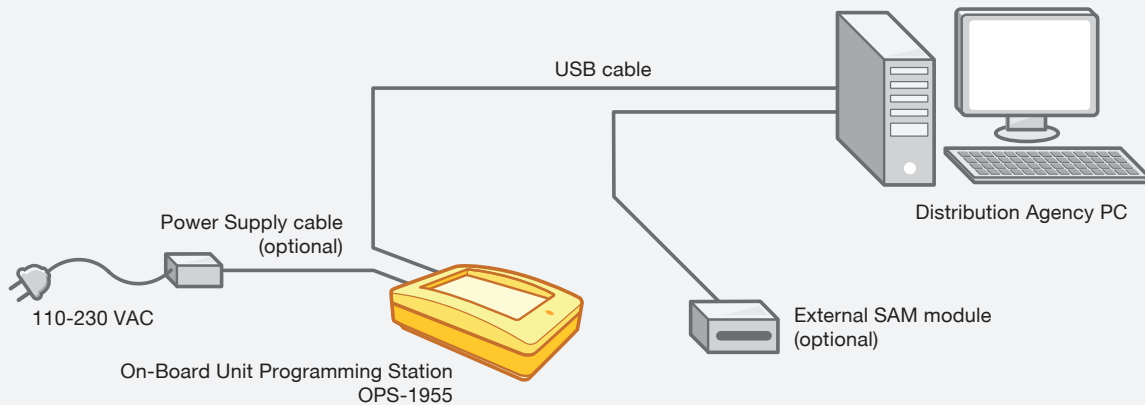

Technical features

DSRC communication in accordance with:

- EN 12253 Physical Layer (Class C)
- EN 12795 Data Link Layer
- EN 12834 Application Layer
- EN 13372 DSRC Profiles
- GSS (Global Specification for Short Range Communication)

Frequency channels

- 5.7975 GHz, 5.8025 GHz
- 5.8075 GHz, 5.8125 GHz

In accordance with:

- EN 300674-2-1 V1.1.1 (2004)
- EN 301489-1 V1.6.1 (2005)
- EN 301489-3 V1.4.1 (2002)
- EN 60950-1 (2001) +A11 (2004)

Dimensions

- 170 x 113 x 48 mm (LxWxH)

Weight

- ~ 500 g

Electrical

- External Power Supply: 5VDC 0.5A
- Power Consumption max 2,5 W (operating mode)

Environmental Conditions

- Operating temperature: -5 to +50 °C
- Storage temperature: -20 to +70 °C
- Ambient Humidity: 5 to 95% (non condensing)

USB Interface

- USB 2.0 Full Speed

Interface Driver

- Windows XP, Windows 2000

Kapsch Group

The companies of the Kapsch Group – Kapsch TrafficCom, Kapsch CarrierCom and Kapsch BusinessCom – are leading the international markets for Intelligent Transportation Systems (ITS) and Information and Communication Technologies (ICT). Kapsch. Always one step ahead.